

# sdc Smart Data Meter E

The compact and powerful power and energy meter

The sdc Smart Data Meter E is a compact and powerful meter for power and energy measurements in low-voltage three-phase systems.



## YOUR BENEFIT

- Transparent energy consumption by means of load profile analyzes
- Compact design - high functionality
- Powerful - power measurement up to 690kW, high storage capacity, high storage dynamics
- No additional costs for software

### Compact design - small dimensions

The sdc Smart Data Meter E measures electrical power and energy in low-voltage three-phase systems. The measured three phase voltage is to be wired to screw-type terminals. For current measurement up to three flexible current transformers per measuring point can be connected. Up to four three-phase measuring inputs can be integrated into one device. Its small dimensions allow mounting under a contact hazard protection cover.

### Easy Installation

The sdc Smart Data Meter E is easily mounted by snapping onto a DIN rail. The flexible current transformers are laid around the supply wires of the measuring object; it is not necessary to disconnect

the measuring object from the mains. A control LED confirms the correct installation. The measurement starts immediately after switching on the supply voltage.

### Powerful Data Recorder

The sdc Smart Data Meter E can be equipped with a data storage up to 128 GB for long-term measurements.

### High dynamics

The dynamic function of the data recorder provides high storage rates of up to 10 values/second and measurement. This provides new transparency of energy consumption: detailed views of the power consumption of several connected consumers are visible at a single measuring point.

### Data output at the touch of a button

Mobile devices such as Smartphone, tablet can connect directly to the integrated Wi-Fi hotspot. All collected measurement data can be displayed in real time – at the push of a button.

### High number of network interfaces

The basic version of the sdc Smart Data Meter E has a LAN and WLAN interface and can also be extended with LoRa® 868 MHz or 4G/LTE modem.

### No software costs

The parameterization and graphical evaluation can be done just using a conventional web browser on your end device.

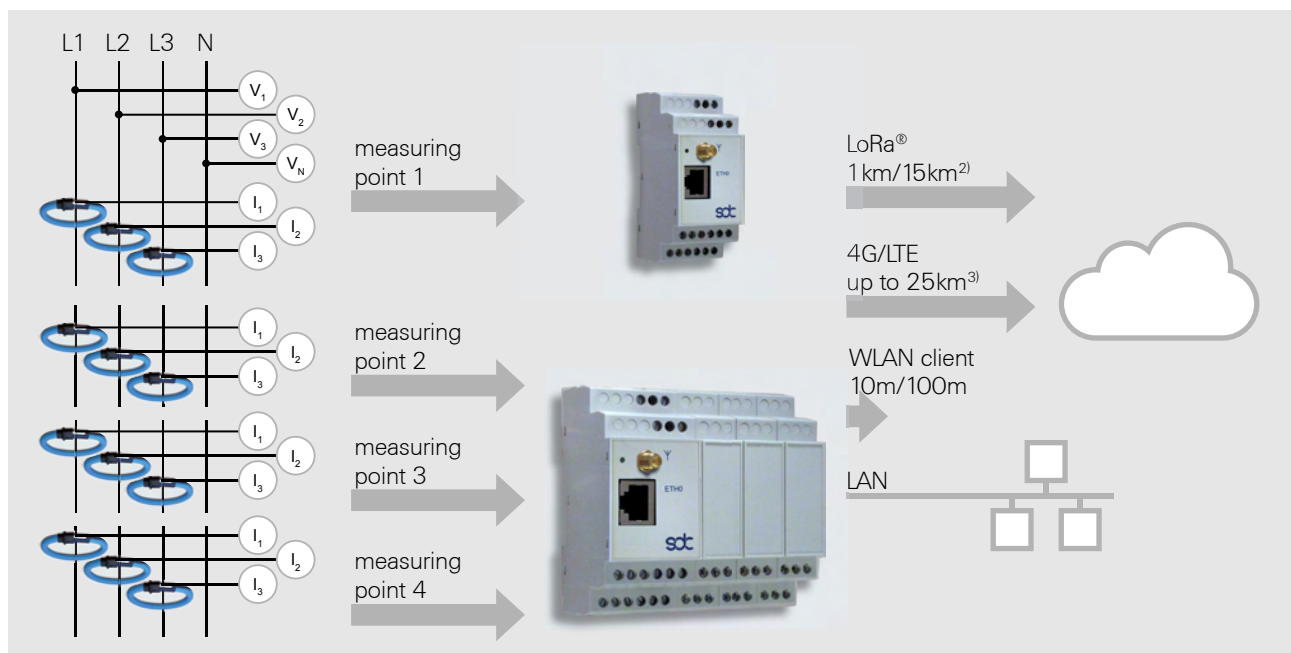

subject to modifications, illustrations similar

2) radio range inside/outside of buildings, maximum 3) extreme far range up to the base station, maximum

Technical Characteristics sdc Smart Data Meter E	
Power range of the measurement objects	1–690 kW
Voltage measurement	3 x 400VAC (L1–L3, N), terminal connection
Current measurement	1 x three-phase measuring point for flexible current transformers up to 1000A, screw-type terminal optional: expandable to up to 4 x three-phase measuring points
Values per three-phase measuring point	phase voltages: 3 x 400 VAC (L1–L3, N) phase currents: 3 x bis 1000A power factor (PF): each phase active power/energy: each phase and total reactive power: each phase and total apparent power: each phase and total multiphase energy measurement: class 0,2S, class 0,5S, class 1
Data interfaces	LAN (Ethernet RJ45) WLAN hotspot 802.11 b/g/n (intern) WLAN client 802.11 b/g/n (external antenna connection) <sup>5)</sup> RS485 (terminal connection) optional: LoRa® 868 MHz (external antenna connection) 4G/LTE modem: IEEE 802.15.4g (external antenna connection)
Data protocols	SMTP (email) optional: FTP, SFTP (data transfer), further on request
Web server	Http, Parameterization, visualization and remote selection of the stored <sup>4)</sup> measured data (CSV files) <sup>4)</sup> via a web browser.
Power supply	5VDC, 3A, (230 VAC via switching power supply)
Dimensions (W x H x D)	ca. 35 mm x 98 mm x 65 mm optional additional width per measuring point: ca. 17,5 mm
Installation	DIN rail
Runtime system	sdc RTE/Linux
Data recorder (optional)	up to 128 GB of onboard memory available data storage format: CSV file
Dynamic function (optional)	adjustable data storage rate up to 10 values/second and measurement

Accessories	
Switching power supply	230 VAC / 5 VDC, 3A, (dimensions W x H x D app. 25 mm x 93 mm x 56 mm)
Flexible current transformers up to 1000A	measuring range: bis 1000A/AC frequency: 20-5000Hz scope: 400 mm accuracy class : 2 measurement category CAT III 1000V @ 50/60Hz (IEC 61010-1) CAT IV 600V @ 50/60Hz

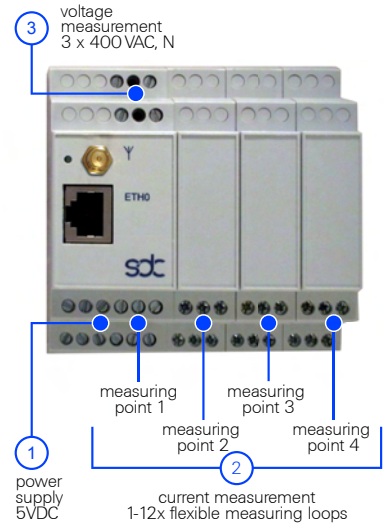
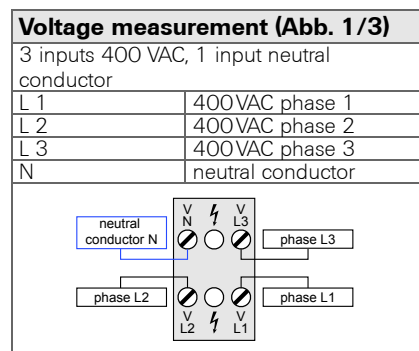
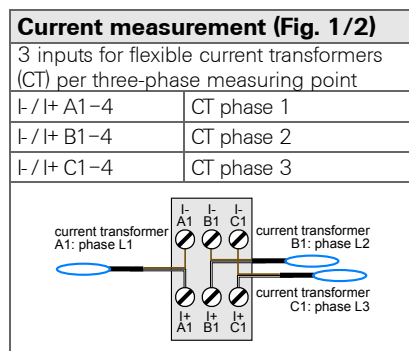
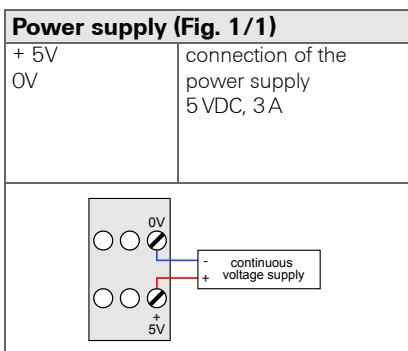

Fig. 1

Order code	
<b>sdc Smart Data Meter E</b>	
ME10 X - X - X - X	
<div style="display: flex; justify-content: space-around; align-items: center;"> <div style="border: 1px solid black; padding: 2px 5px;">A</div> <div style="border: 1px solid black; padding: 2px 5px;">-</div> <div style="border: 1px solid black; padding: 2px 5px;">B</div> <div style="border: 1px solid black; padding: 2px 5px;">-</div> <div style="border: 1px solid black; padding: 2px 5px;">C</div> <div style="border: 1px solid black; padding: 2px 5px;">-</div> <div style="border: 1px solid black; padding: 2px 5px;">D</div> </div>	
<b>A</b>	<b>Number of three-phase current measuring points integrated in one device</b> 1: 1 2: 2 3: 3 4: 4
<b>B</b>	<b>Data recorder</b> 0: none 1: data recorder 8GB 2: data recorder 128 GB 3: data recorder 8 GB dynamic 4: data recorder 128 GB dynamic
<b>C</b>	<b>Data interfaces</b> 0: LAN, WLAN-Hotspot (internal), RS485 in addition 1: WLAN client (external) 2: LoRa® 3: 4G/LTE modem
<b>D</b>	<b>Data protocols</b> 0: SMTP (email), Standard http in addition 1: FTP, SFTP X: specific on request



subject to modifications, illustrations similar

4) prerequisite: option data recorder 5) with option LoRa® only for parameterization, as antenna connection is used for LoRa®

Product Line  
sdc Smart Data Systems 2018



**sdc Smart Data Communication GmbH**

Am Bahnhofplatz 7  
D-76571 Gaggenau  
Germany

Tel: +49 (0) 7225 / 605 992 0

Email: [info@smart-data-communication.com](mailto:info@smart-data-communication.com)  
Internet: [www.smart-data-communication.com](http://www.smart-data-communication.com)

